

Solid State Broadband High Power Amplifier

2187
1000 - 3000 MHz / 500 Watts

The 2187 is suitable for high bandwidth, high power CW, modulated, and pulse applications. This amplifier utilizes high power GaN on SiC devices that provide wide frequency response, high gain, high peak power capability, and low distortions. Exceptional performance, long-term reliability and high efficiency are achieved by employing advanced broadband RF matching networks and combining techniques, EMI/RFI filters, and all qualified components. The amplifier is constructed within one single 3RU drawer including the forced air-cooling. Available operating voltage configurations are single-phase 180-260 VAC up to 400 Hz and 28 VDC.

SKU#: 2187-001

The amplifier includes a built-in control and monitoring system, with protection functions which preserve high availability. Remote management and diagnostics are via an embedded web server allowing network managed site status and control simply by connecting the unit's Ethernet port to a LAN. Using a web browser and the unit's IP address (IPv4) allows ease of access with the benefit of multi-level security. The control system core runs an embedded OS (Linux), has a built-in non-volatile memory for event recording, and factory setup recovery features. The extended memory option allows storage of control parameters and event logs.

Empower RF's ISO9001:2015 Quality Assurance Program assures consistent performance and the highest reliability.

- Solid-state class AB compact modular design
- Suitable for CW, AM, FM and pulse (Consult factory for other modulation types)
- Embedded directional coupler – Eliminates the need for external component
- 50 ohm input/output impedance
- Built-in Control, Monitoring and Protection functions
- High reliability and ruggedness

ELECTRICAL SPECIFICATIONS over temperature conditions (-10 to +40°C)

Parameter	Symbol	Min	Typ	Max	Unit
Operating Frequency	BW	1000		3000	MHz
Power Output CW <i>Notes 1, 3</i>	P _{SAT}	500			Watt
Power Output @ 1dB Gain Compression <i>Note 2</i>	P _{1dB}	400			Watt
Power Gain @ 1dB Gain Compression	G _{1dB}	57			dB
Input Power for Rated P _{SAT}	P _{IN}		0		dBm
Input Power Range	P _{IN}	-3.0		+3.0	dBm
Gain Flatness / Leveled ALC	ΔG			±3.5/±1.5	dB
Gain Adjustment Range @ P _{IN} = -30dBm	VVA	20			dB
Input Return Loss	S ₁₁			-10	dB
Noise Figure @ maximum gain	NF			20	dB
Third Order Intermodulation Distortion 2-Tone @ 51dBm/Tone, 1MHz Spacing	IM3		-20		dBc
Harmonics @ P _{OUT} = 500W	2 ND			-10	dBc
	3 RD			-20	dBc
Spurious Signals	Spur			-60	dBc
Operating Voltage	V _{AC}	180	220	260	Volt
	V _{DC}	24	28	32	
Power Consumption @ 500W CW	P _D			3000	VA

Notes: 1. CW measurement performed in MGC Mode (Manual Gain Control)
 2. P_{1dB} measurements performed with AM 80% depth of modulation, 1 kHz modulation signal.
 3. The front RF connectors option output power is less by up to 1.00 dB due to added insertion loss of the RF cable routed to the front panel.

MECHANICAL SPECIFICATIONS

Parameter	Value	Unit
Dimensions W x H x D (excludes connectors, handles and brackets)	17 x 5.25 x 22	Inch
Weight	80	Pound
RF Connectors Input/Output	N-type, Female	RF INPUT / RF OUTPUT
RF Sample Connectors	SMA, Female	FWD / REV
Blanking/Gating Input Connector	BNC, Female	Blanking
Cooling	Built-in forced air-cooling system – front to rear	Airflow direction

Solid State Broadband High Power Amplifier

2187
1000 - 3000 MHz / 500 Watts
ENVIRONMENTAL CHARACTERISTICS (Qualification Data available for review):

Parameter	Symbol	Min	Typ	Max	Unit
Operating Ambient Temperature *	T _A	-10 *		+40	°C
Non-operating Temperature *	T _{STG}	-20 *		+85	°C
Relative Humidity (non-condensing)	RH			95	%
Shock / Vibration - MIL-STD-810F Shock Method 516.5, Vibration Method 514.5	SH / VI				

Note: [*] Consult Empower RF for application conditions below -10°C / -20°C temperatures (Operational / Non-operational).

PROTECTIONS:

Parameter	Specification	Unit
Input Overdrive	+10 dBm	Max
VSWR protection	At 3:1 – PA backs-off output power to a safe operating level – no system shutdown, “On Air” time is maximized	-
Thermal – Graceful Degradation	Ambient 40°C	Min
Default Data Recovery	Factory Default Calibration Recovery	

COMMUNICATION INTERFACES:

Function	Utility	Connector
Ethernet	Network management of device / web interface	RJ45
USB	Mass storage / Expansion Bus	USB 1.x/2.0 compatible
RS232, default [RS422, factory configurable]	Serial management of device / local operator access	D-Sub 9-position Male

SYSTEM I/O CONNECTOR – 14-Position

Pin #	Description	Specification
1	FWD TP	Forward detected power (analog voltage: 0-5 Volt)
2	REV TP	Reverse detected power (analog voltage: 0-5 Volt)
3	Summary Fault	Summary Fault: Active TTL Logic Low ($\leq 0.7V$), (<i>Internally Pulled-High</i>)
4	Reserved	No Connection
5	Shutdown	Amplifier Disable: TTL Logic Low ($\leq 0.7V$), (<i>Internally Pulled-High</i>)
6	Aux P/S TP	+12.0V _{DC} $\pm 2V$ (resettable 0.5amp fuse)
7	Main P/S TP	+48.0V _{DC} $\pm 4.8V$ (resettable 0.5amp fuse)
8	GND	Ground
9-11	Open drain control	Site management utility (reserved)
12&13	Digital I/O (configurable)	Site management utility (reserved)
14	GND	Ground

AVAILABLE OPTIONS

2187-XXX
-001 - 180-260VAC, 1-ph, Rear RF Connectors
Contact us for other available options
Standard Features:
-LCD Control, Ethernet & Serial Comm
-Main RF Connectors: Input & Output [N-type Female]
-RF Sample Ports: Forward & Reverse [SMA Female]
-Blanking/Gating Port: BNC Female
-Rack Slides, Handles and Rackmount Bracket

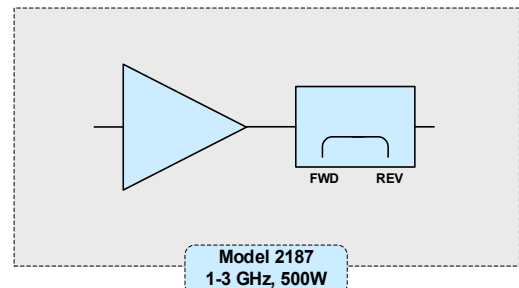
NOTIONAL BLOCK DIAGRAM

Solid State Broadband High Power Amplifier

2187

1000 - 3000 MHz / 500 Watts

MECHANICAL OUTLINE [with rear RF connectors]

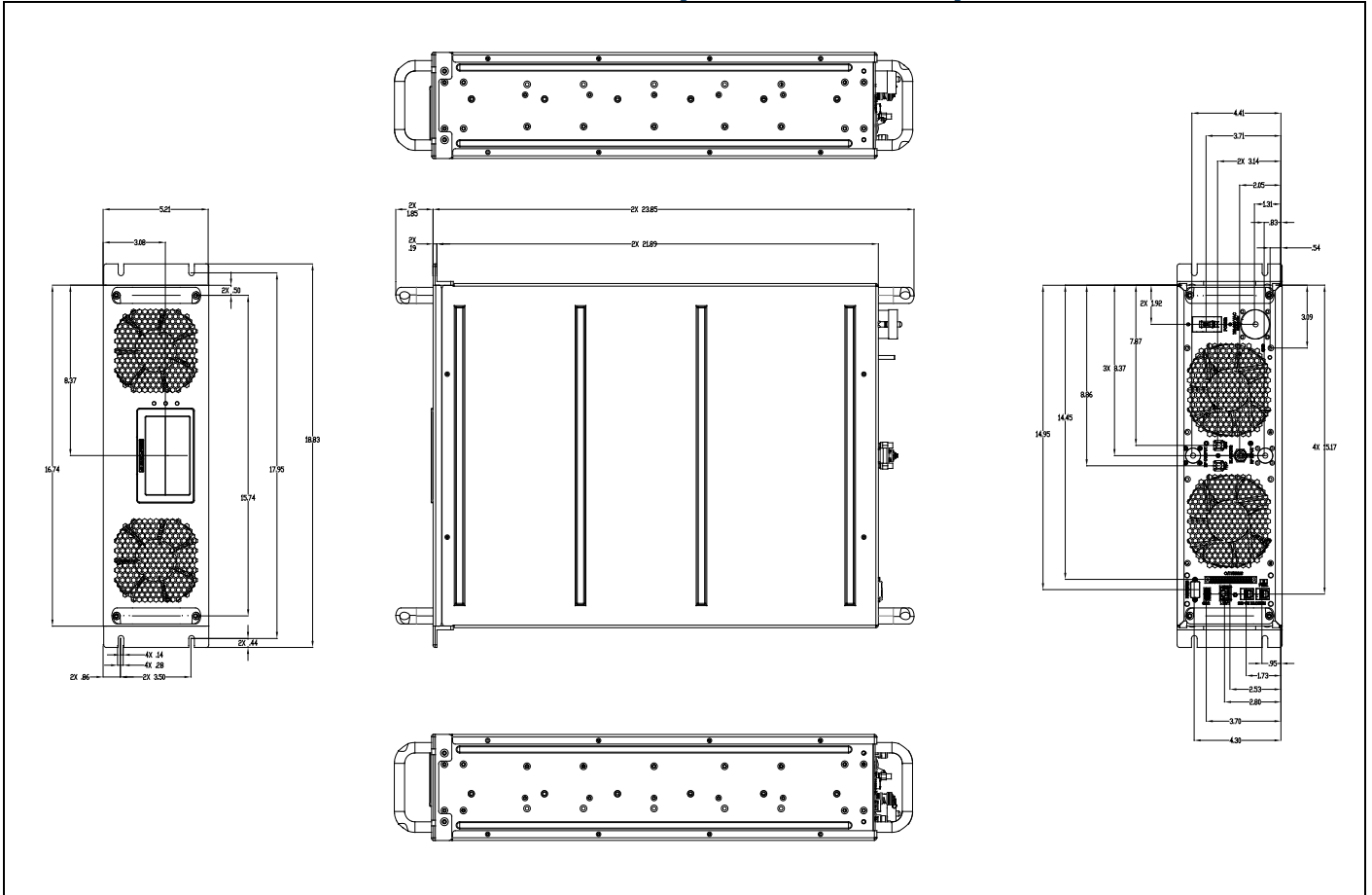

Front and Rear Views

