

Solid State Broadband High Power Amplifier

2193
1000 - 3000 MHz / 80 Watts

The 2193 is suitable for octave bandwidth high power CW, modulated, and pulse applications. This amplifier utilizes high power GaN devices that provide wide frequency response, high gain, high peak power capability, and low distortions. Exceptional performance, long-term reliability and high efficiency are achieved by employing advanced broadband RF matching networks and combining techniques, EMI/RFI filters, and all qualified components. The amplifier is constructed within one single 3RU drawer including the forced air-cooling. Available operating voltage configurations are single phase 100-240 VAC up to 400Hz and 28 VDC.



SKU#: 2193-001

The amplifier includes a built-in control and monitoring system, with protection functions which preserve high availability. Remote management and diagnostics are via an embedded web server allowing network managed site status and control simply by connecting the unit's Ethernet port to a LAN. Using a web browser and the unit's IP address (IPV4) allows ease of access with the benefit of multi-level security. The control system core runs an embedded OS (Linux), has a built-in non-volatile memory for event recording, and factory setup recovery features. The extended memory option allows storage of control parameters and event logs.

Empower RF's ISO9001:2015 Quality Assurance Program assures consistent performance and the highest reliability.

- Solid-state Class AB compact modular design
- Suitable for CW, AM, FM, Pulse and some linear applications (Consult factory for other modulation types)
- Embedded directional coupler – Eliminates the need for external component
- 50 ohm input/output impedance
- Built-in Control, Monitoring and Protection functions
- High reliability and ruggedness

ELECTRICAL SPECIFICATIONS over temperature conditions (-10 to +40°C)

Parameter	Symbol	Min	Typ	Max	Unit
Operating Frequency	BW	1000		3000	MHz
Power Output CW (Note 1&3)	P _{SAT}	80	100		Watt
Power Output @ 1dB Gain Compression (Note 2)	P _{1dB}	60	80		Watt
Power Gain @ 1dB Gain Compression	G _{1dB}	49			dB
Input Power for Rated P _{SAT}	P _{IN}		0	5	dBm
Input Power Range	P _{IN}	-5.0		+5.0	dBm
Small Signal Gain Flatness / Leveled ALC	ΔG			±3.5/±1.0	dB
Gain Adjustment Range	VVA	20			dB
Input Return Loss	S ₁₁			-10	dB
Noise Figure @ maximum gain	NF			20	dB
Third Order Intermodulation Distortion 2-Tone @ 44dBm/Tone, 1MHz Spacing	IM3		-20		dBc
Harmonics @ P _{OUT} = 80W	2 ND		-25	-17	dBc
	3 RD		-30	-25	
Spurious Signals	Spur			-60	dBc
Operating Voltage	V _{AC}	100		240	Volt
	V _{DC}	24	28	32	
Power Consumption @ 80W CW	P _D		500	750	VA

Notes: 1. CW measurement performed in MGC Mode (Manual Gain Control)
 2. P_{1dB} measurements performed with AM 80% depth of modulation, 1 kHz modulation signal.
 3. The front RF connectors option output power is less by up to 1.00 dB due to added insertion loss of the RF cable routed to the front panel.

MECHANICAL SPECIFICATIONS

Parameter	Value	Unit
Dimensions W x H x D (excludes connectors, handles and brackets)	17 x 5.25 x 22	Inch
Weight	65	Pound
RF Connectors Input/Output	N-type, Female	RF INPUT / RF OUTPUT
RF Sample Connectors	SMA, Female	FWD / REV
Blanking/Gating Input Connector	BNC, Female	BLANKING
Cooling	Built-in forced-air cooling system – front to rear	Airflow Direction

Solid State Broadband High Power Amplifier

2193
1000 - 3000 MHz / 80 Watts
ENVIRONMENTAL CHARACTERISTICS (Qualification Data available for review)

Parameter	Symbol	Min	Typ	Max	Unit
Operating Ambient Temperature	T _A	-10		+40	°C
Non-operating Temperature	T _{STG}	-40		+85	°C
Relative Humidity (non-condensing)	RH			95	%
Shock / Vibration - MIL-STD-810F Shock Method 516.5, Vibration Method 514.5	SH / VI				

PROTECTIONS

Parameter	Specification	Unit
Input Overdrive	+10 dBm	Max
VSWR Protection	At 3:1 – PA backs-off output power to a safe operating level – no system shutdown, “On Air” time is maximized	-
Thermal – Graceful Degradation	Ambient 40°C	Min
Default Data Recovery	Factory Default Calibration Recovery	

COMMUNICATION INTERFACES

Function	Utility	Connector
Ethernet	Network management of device / web interface	RJ45
USB	Mass storage / Expansion Bus	USB 1.x/2.0 compatible
RS232, default (RS-422, factory configurable)	Serial management of device / local operator access	D-Sub 9-position Male

SYSTEM I/O INTERFACE – 14-Position

Pin #	Description	Specification
1	N/C	No Connection (reserved)
2	N/C	No Connection (reserved)
3	Summary Fault	Summary Fault: Active TTL Logic Low ($\leq 0.7V$), (<i>Internally Pulled-High</i>)
4	Reserved	No Connections
5	Shutdown	Amplifier Disable: TTL Logic Low ($\leq 0.7V$), (<i>Internally Pulled-High</i>)
6	Aux P/S Test Point	+12.0V _{DC} $\pm 2.0V$ (resettable 0.5amp fuse)
7	Main P/S Test Point	+44.0V _{DC} $\pm 4.8V$ (resettable 0.5amp fuse)
8	GND	Ground
9-11	Open drain control	Site management utility (reserved)
12&13	Digital I/O (configurable)	Site management utility (reserved)
14	GND	Ground

AVAILABLE OPTIONS

2193-00X
-001 100-240VAC, 1-PH, 47-63 Hz, Rear RF Connectors
-002 28 VDC, Rear RF Connectors
-003 100-240VAC, 1-PH, 47-63 Hz, Front RF Connectors <i>NOTE 3</i>
-004 28VDC, Front RF Connectors <i>NOTE 3</i>
Contact us for other available options; sales@empowerrf.com
Standard Feature:
-LCD Control, Ethernet & Serial Comm
-Main RF Connectors: Input & Output [Type-N, F]
-Sample Port: SMA-F [Forward & Reverse]
-Blanking/Gating Port: BNC-F
-Rack Slides, Handles and Rackmount Bracket

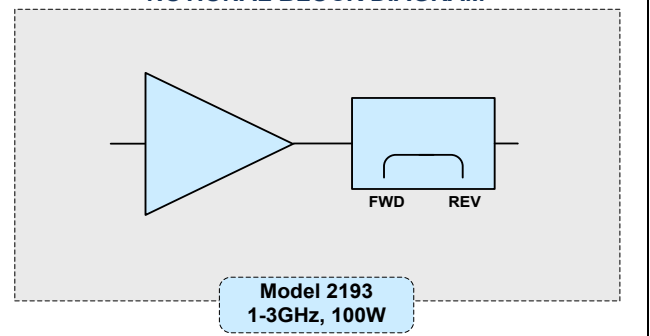
NOTIONAL BLOCK DIAGRAM

Solid State Broadband High Power Amplifier

2193

1000 - 3000 MHz / 80 Watts

MECHANICAL OUTLINE - (Shown with rear RF connectors)

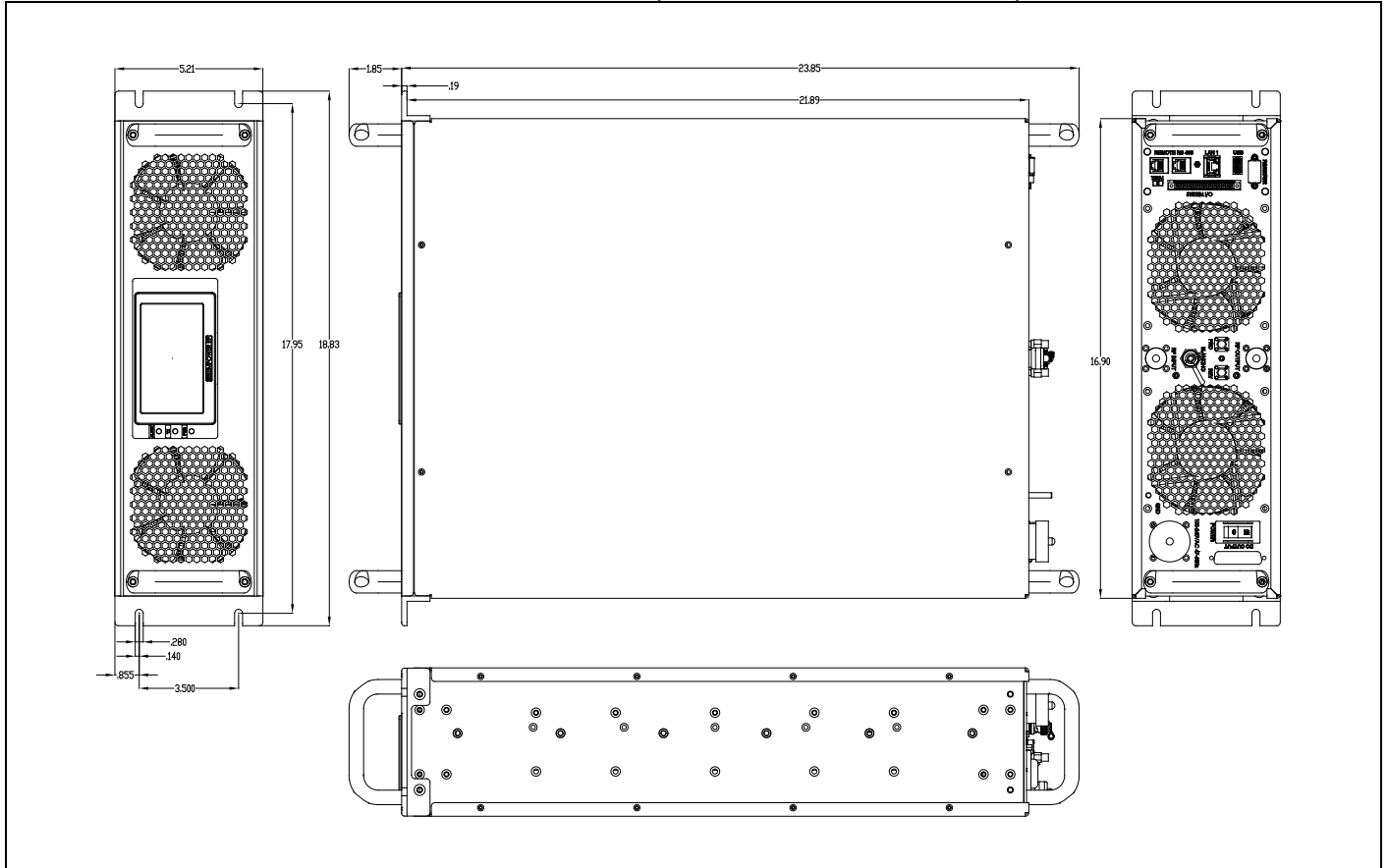

Front and Rear Views

